

Singular Projects

Unnom

Pol. Ind. Les Guixeres

Carrer del Plàstic, 14

08915 Badalona

Tel. 933 950 905

unnom@unnom.es

www.unnom.es

Concepto y diseño

la Negreta

Singular Projects





Dinos qué necesitas
How can we help you?

En **Unnom** te ayudamos a equipar tus instalaciones con elementos singulares contando con un equipo de más de 30 años de experiencia. Escuchamos tus necesidades para diseñar y fabricar todo aquello que precisas y convertimos tus ideas y exigencias en realidades. Somos un equipo experimentado e ilusionado que combinamos diseño, ingeniería, fabricación e instalación, con el objetivo de ofrecerte soluciones personalizadas para cualquier espacio contract.

*With over 30 years of experience, **Unnom's** team is perfectly placed to fit out your facilities with singular products. We listen to your needs so that we can design and manufacture exactly what you want and make your ideas and requirements a reality.*

We are a keen and experienced team combining design, engineering, manufacturing and installation skills with the aim of providing you with bespoke solutions for any corporate space.

Papeleras		Pizarras	
<i>Wastepaper bins</i>	8	<i>Blackboards</i>	93
kai.....	8	arnage.....	93
won.....	14	Señalética	
kra.....	22	<i>Signage</i>	94
siva.....	28	derek.....	94
momo.....	32	Accesorios de oficina	
mina.....	34	<i>Office accessories</i>	100
visnu.....	38	gret.....	100
vai.....	42	youme.....	103
nala.....	46	Brazos portapantallas	
pick'up.....	50	<i>Monitor mounts</i>	106
tribu.....	54	flo.....	106
eco.....	56	ollin.....	108
clinic.....	57	lima.....	109
step.....	58	oripura.....	110
Jardineras		avvc.....	111
<i>Planters</i>	60	plug & play.....	112
gaia.....	60	Fonoabsorbentes	
kai.....	64	<i>Sound absorbing products</i>	114
talia.....	66	eclipse.....	114
pick'up.....	68	canopée.....	115
Atril		swell.....	116
<i>Lectern</i>	70	newport.....	117
nora.....	70	oasis.....	118
Merchandising.....	74	windo.....	119
tea.....	74	madison.....	120
Mesas y carros		kp+.....	121
<i>Tables and trolleys</i>	80	ke.....	121
tab.....	80	addenda.....	122
Percheros		Lámparas	
<i>Racks</i>	84	<i>Lamps</i>	124
amy.....	84	scoop.....	124
sherwood.....	88	ipn.....	125
kobé.....	90		
sherpa.....	91		
arnage.....	92		

kai

Para cualquier espacio
Perfect for any space

Si buscas papeleras y paragüeros que encajen a la perfección en cualquier ubicación, ambiente y entorno, **KAI** es la familia que necesitas. Su diseño minimalista y funcional permite una colocación individual, alineada o en forma de islas.

Versiones con cabezal abatible o extraíble que facilitan su uso como papeleras de reciclaje, paragüeros o, incluso, jardineras.

*If you're looking for wastepaper bins and umbrella stands that will suit any location, room or setting, then **KAI** is the range you need. Its minimalist yet functional design means these products can be used individually, lined up or set in an island shape.*

Versions with a tilting or removable top making them easy to use as recycling bins, umbrella stands and even planters.

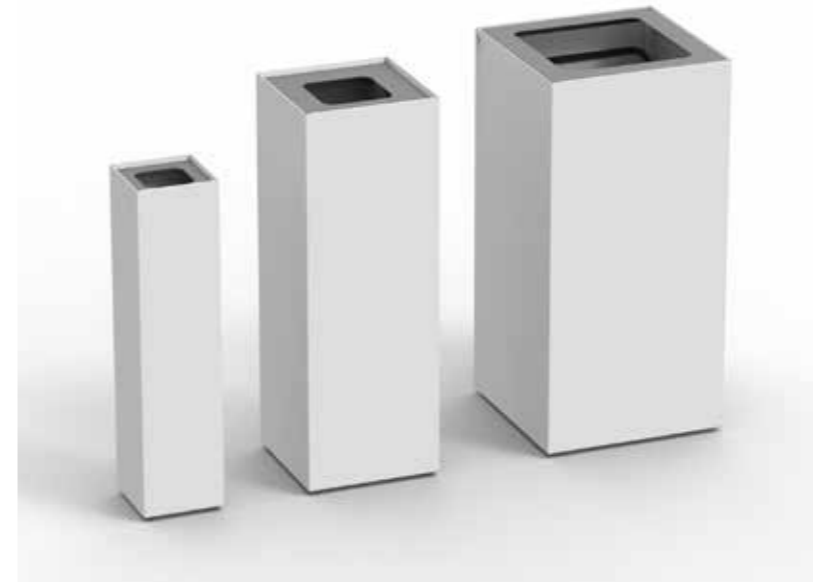

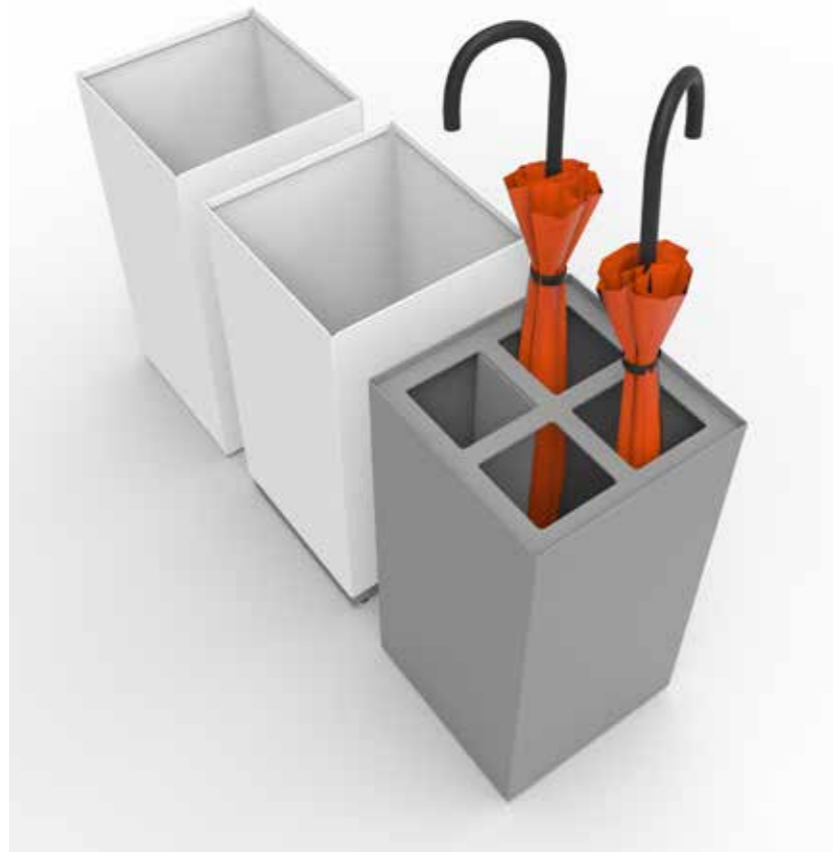

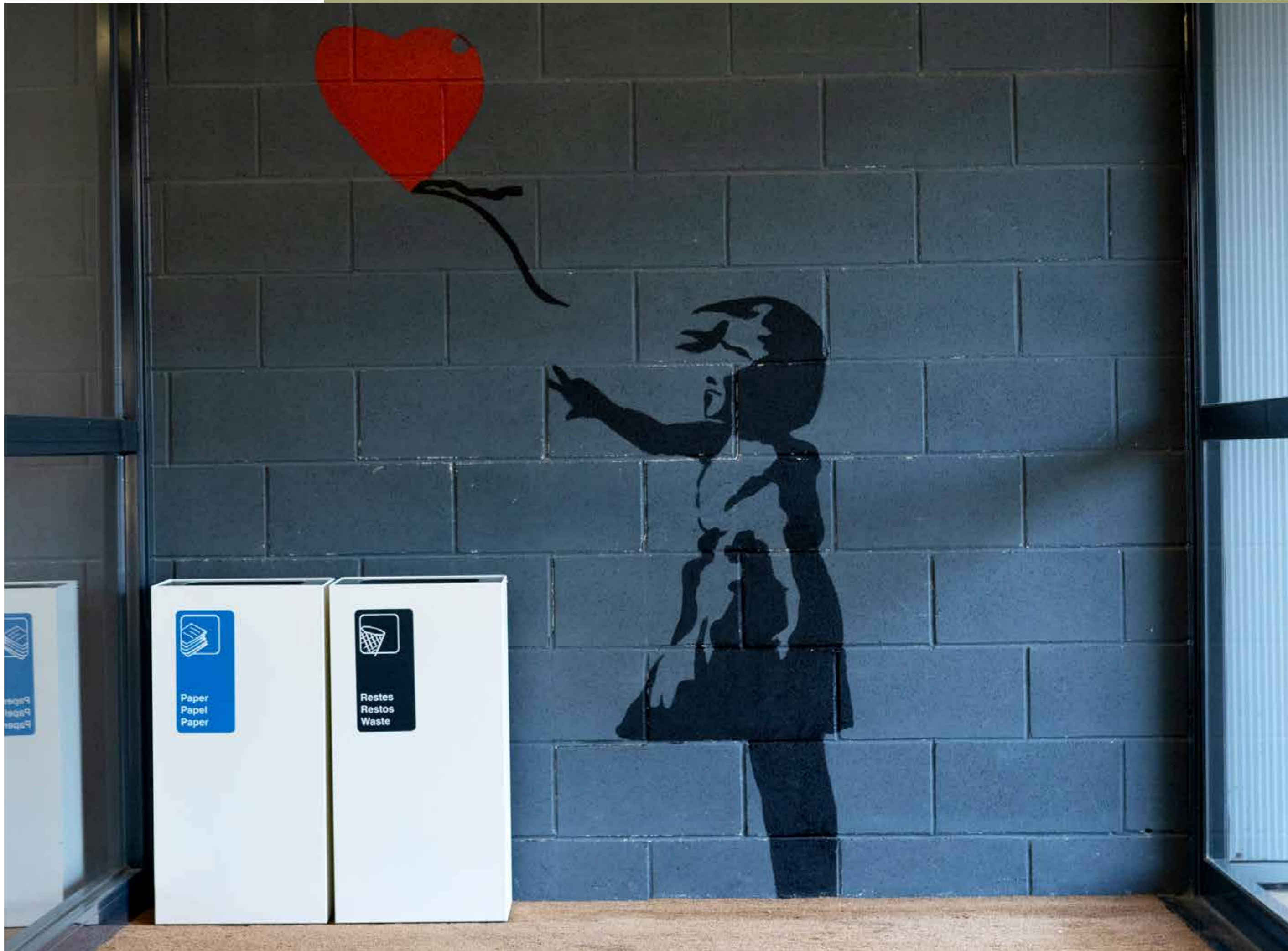

won

Reciclaje funcional
Functional recycling

WON es una familia de papeleras cilíndricas diseñada específicamente para fomentar el reciclaje. Incorporan aro porta bolsas, bisagra de retención, identificador de residuos y la opción de mástil señalizador para facilitar la localización en grandes espacios. Autoportantes o fijadas al suelo, de forma individual o en formato isla de 3 y 4 elementos para reciclar distintos tipos de residuos. Según tus necesidades puedes elegir modelos completamente opacos, semiopacos que permiten ver parte del interior, o semitransparentes que permiten ver todo su contenido.

***WON** is a range of cylindrical wastepaper bins specifically designed to encourage recycling. They have a bin bag hoop, detent hinge, waste identification label and an optional signpost to make it easier to locate in large spaces. Self-supporting or fixed to the floor, individual or island format with 3 or 4 bins for opaque, semi-opaque providing a partial view of the inside or semi-transparent allowing you to see all their content.*





won

Papeleras / Wastepaper bins



Accesorio limitador de objetos de volumen
Volume limiter accessory

/ 16 /

/ 17 /





/ 18 /

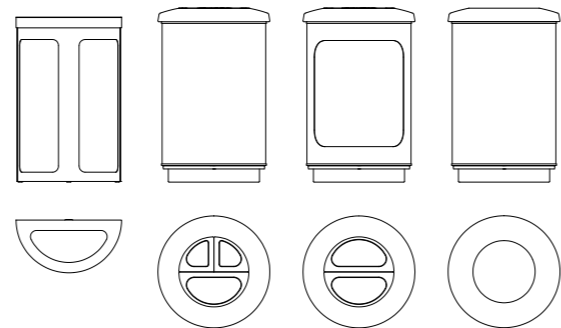

/ 19 /



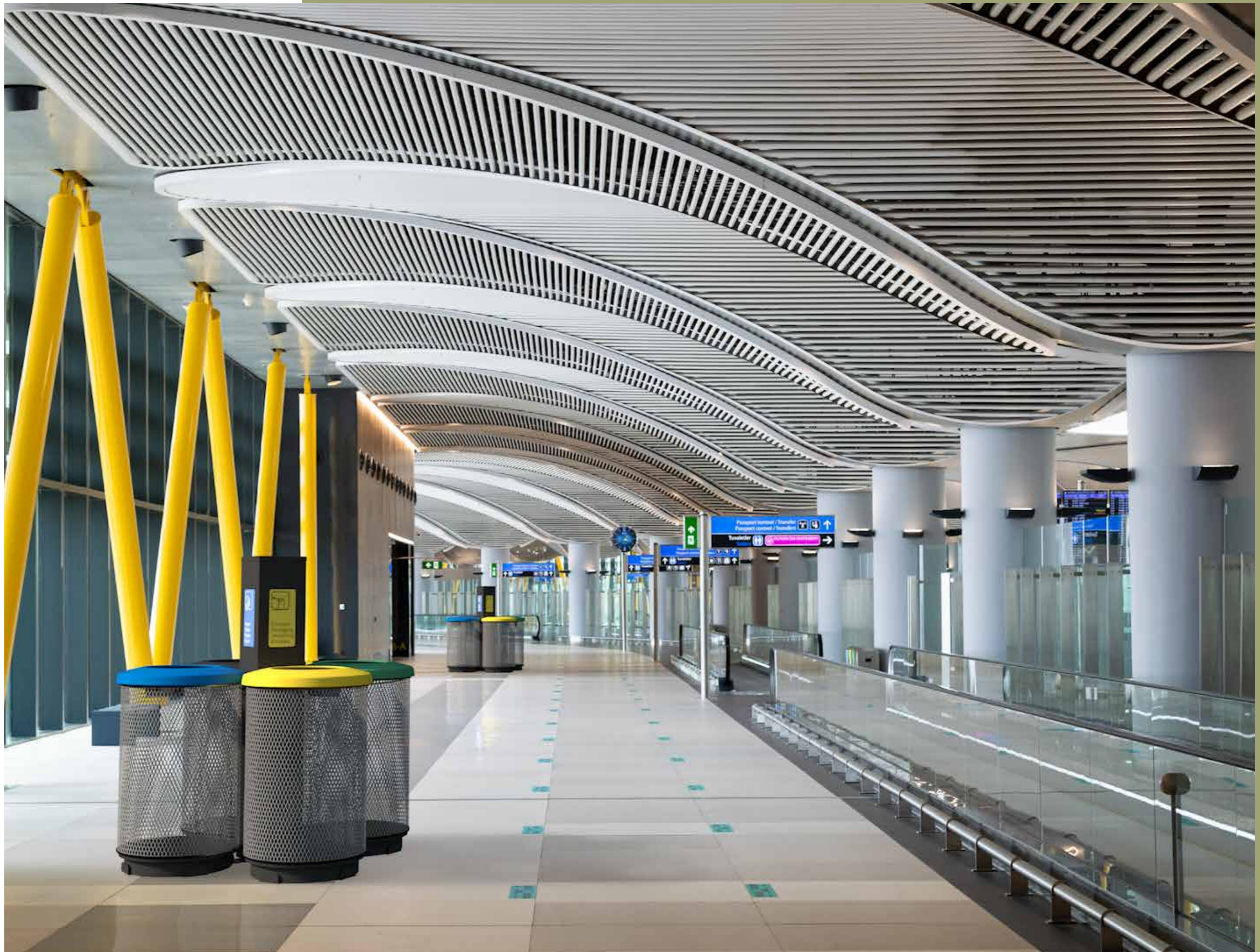

kra

Reciclaje de gran capacidad High volume recycling

Si lo que necesitas son papeleras y contenedores de gran capacidad **KRA** es la solución perfecta para ti. Tienes una gran variedad de diseños y opciones para elegir: boca superior de grandes dimensiones que facilita el vertido, diferentes orificios según el tipo de residuo con cabezal horizontal o inclinado y orificios frontales con o sin tolva. Todos los modelos incorporan puerta frontal que facilita la extracción de la bolsa. Fabricada en distintos colores y con pictogramas que facilitan la rápida identificación del residuo, incluyendo un modelo especial para depositar objetos peligrosos o prohibidos en áreas con restricciones.

*If you need large volume wastepaper bins and containers, then look no further than **KRA**. There's a wide variety of designs and options to choose from: a large top opening that makes emptying easy, different openings depending on the type of waste with a horizontal or tilting top, and front openings with or without a chute. All models have a front door to make bag removal easy. They are manufactured in different colours with picture diagrams to help with waste identification, including a special model for depositing hazardous objects or prohibited articles in restricted areas.*





/ 24 /



/ 25 /

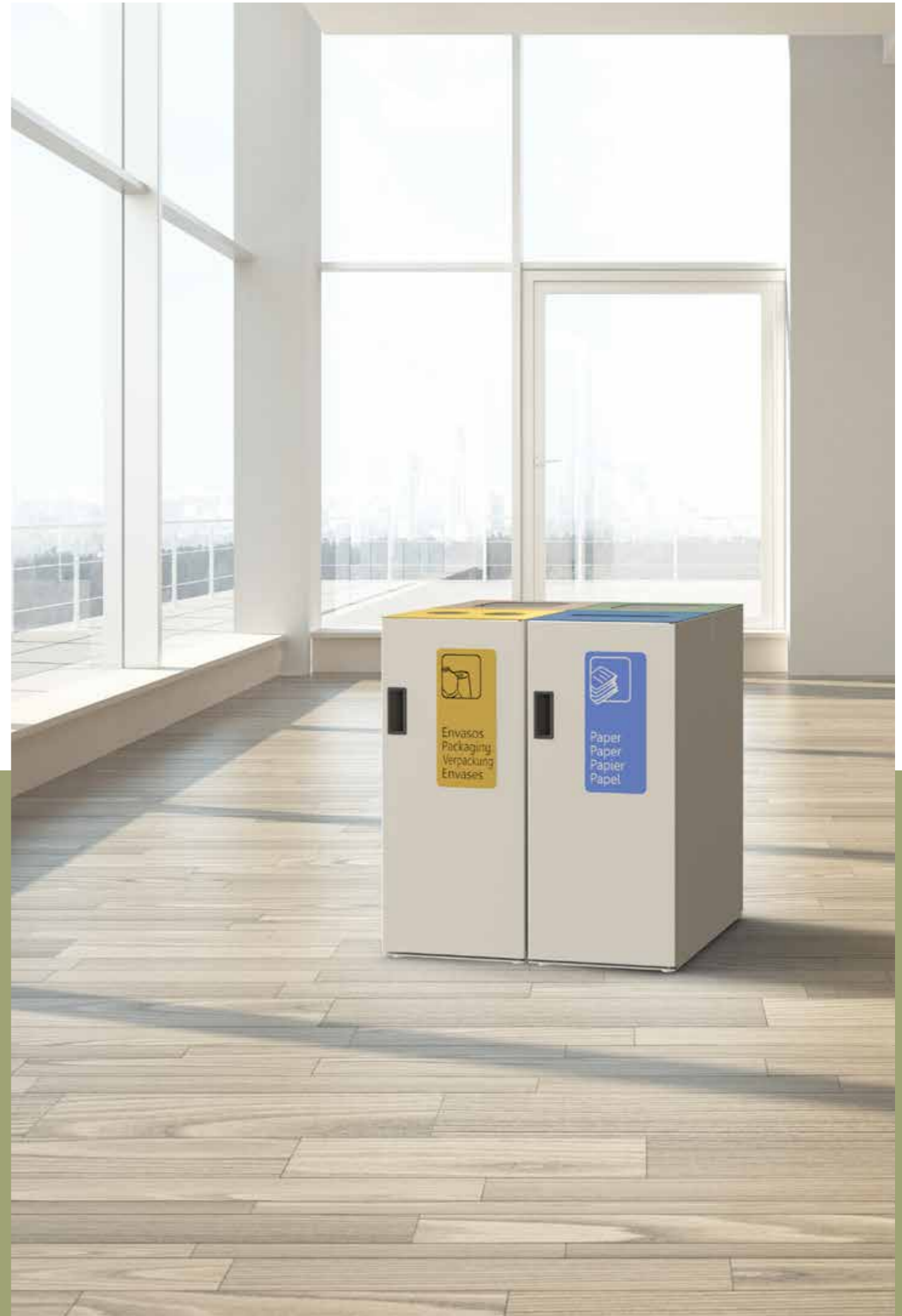
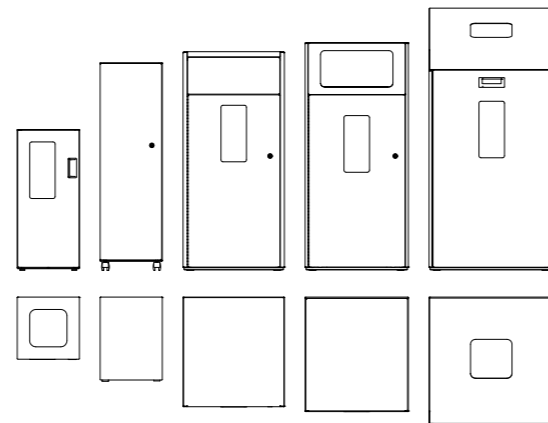

siva

Hasta 5 tipos de residuos
Up to 5 types of waste

La familia de papeleras **SIVA** está diseñada para el reciclaje selectivo de 1 a 5 tipos de residuos y fabricada en diferentes formatos y capacidades. Todos los modelos incluyen cabezales abatibles con identificador de color, bisagras con retención del cabezal que facilitan el vaciado de la papeleras y aristas redondeadas. Están disponibles con aros porta bolsas o cubetas metálicas de extracción superior.

*The **SIVA** range of wastepaper bins is designed for selective recycling of one to five types of waste and is manufactured in different formats and capacities. All the models include tilting tops with colour identifiers, detent hinges that make it easier to empty the wastepaper bin, and rounded edges. They are available with a bin bag hoop or metal bucket for hassle-free removal.*

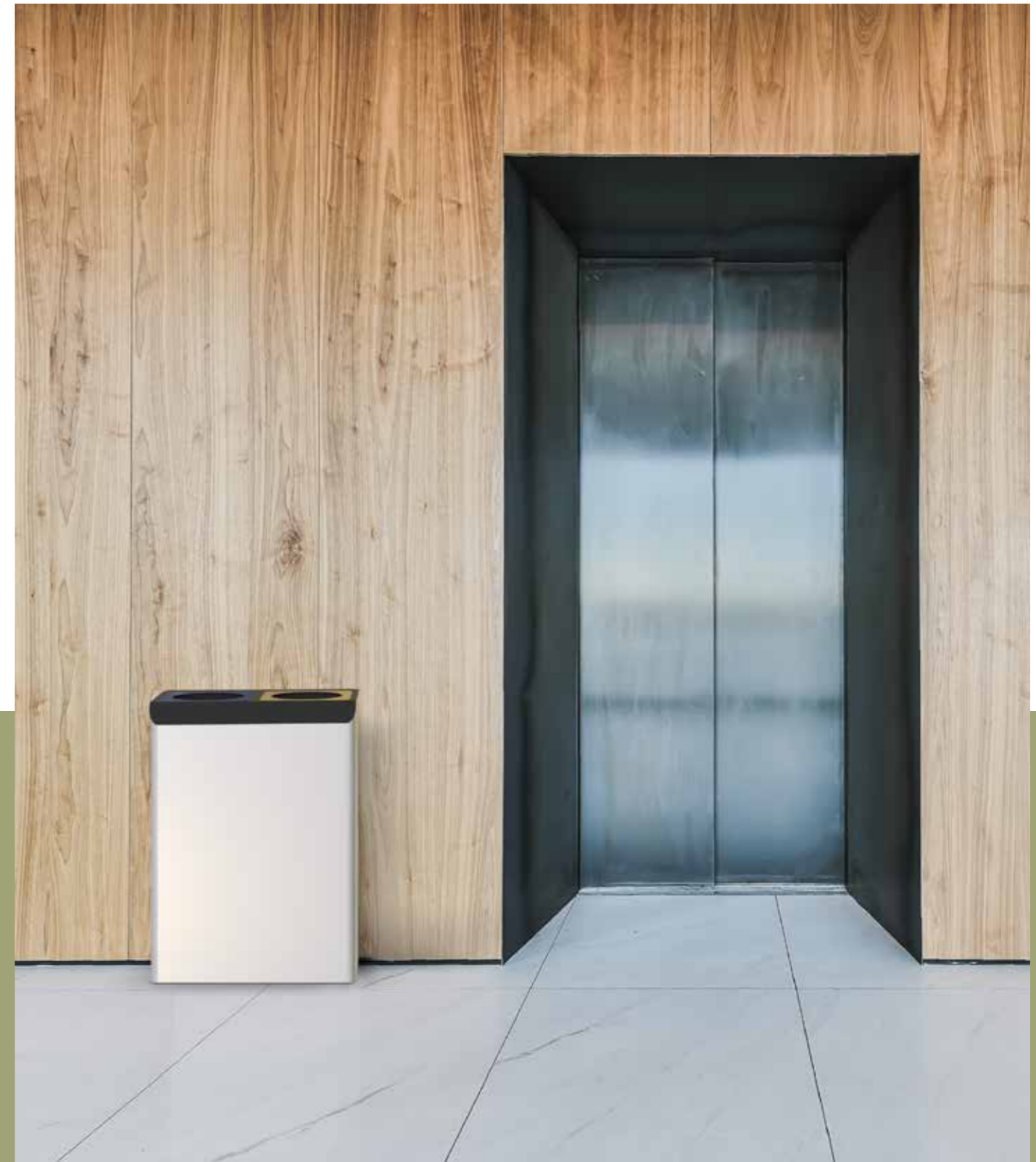



1241x318x750 mm
Cap. 3x80 l.



1176x348x7840mm
Cap. 4x70 l.



1450x348x840 mm
Cap. 5x70 l.

momo

Papeleras Metálicas
Metal Bins

Las papeleras metálicas **MOMO** para 1, 2 o 3 residuos son el elemento perfecto para su instalación en cualquier espacio. Su diseño funcional y plano permite su colocación y adaptación en lugares reducidos.

***MOMO** metal bins for 1, 2 or 3 waste are the perfect element for installation in any space. Its functional and flat design allows its placement and adaptation in small places.*

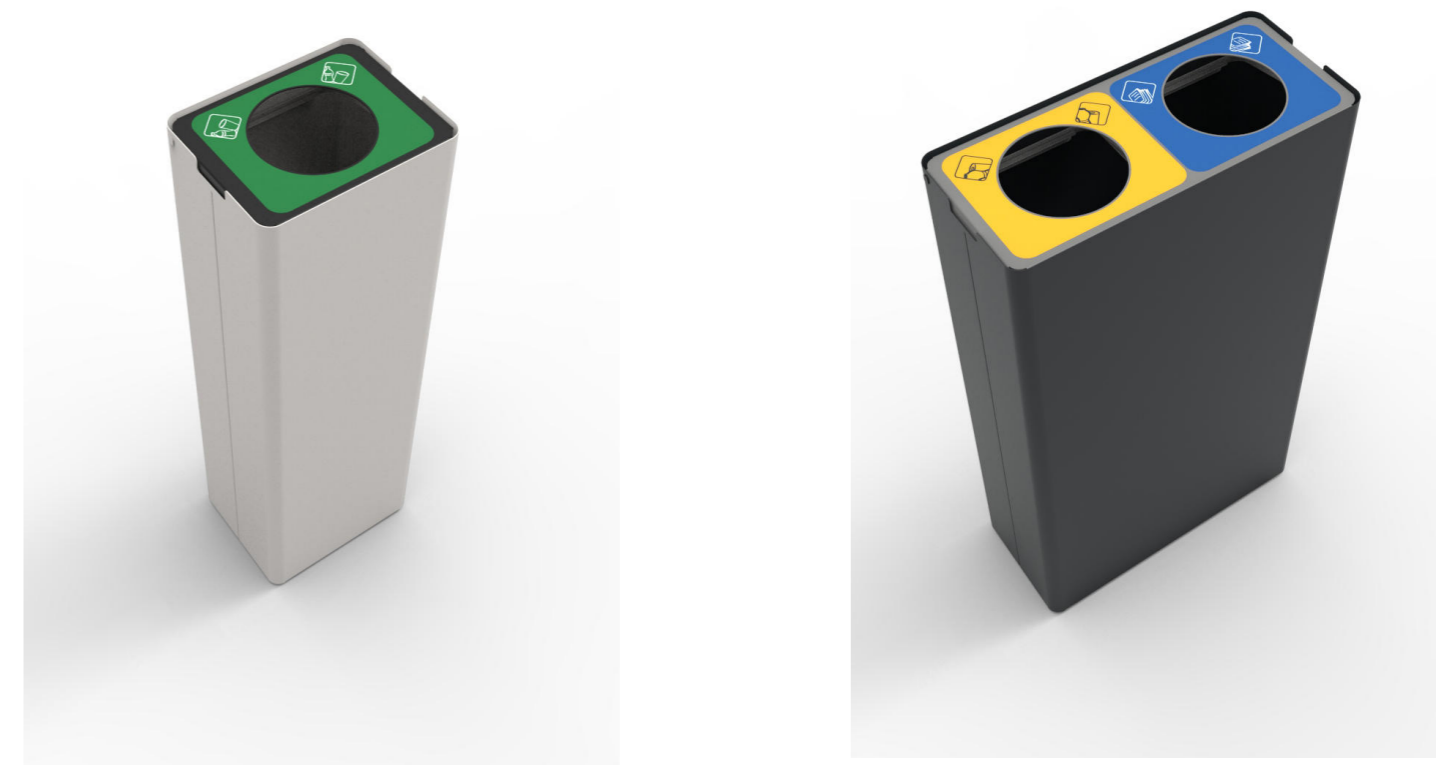

mina

Simplicidad en diversos tamaños
Simplicity in all sizes

Esta colección de papeleras cilíndricas te ofrece una gran versatilidad, con capacidades entre 15 y 80 litros que se adaptan exactamente a las necesidades de cada espacio. Su diseño minimalista sólo incluye un cuerpo y un cabezal que fija la bolsa de plástico y oculta el sobrante, lo que facilita su uso.

This collection of cylindrical wastepaper bins is highly versatile, with capacities of 15 to 80 litres that can be adapted to suit the needs of each room. Their minimalist design features only a body and a top keeping the plastic bag in place and hiding the rest, which makes it easier to use.

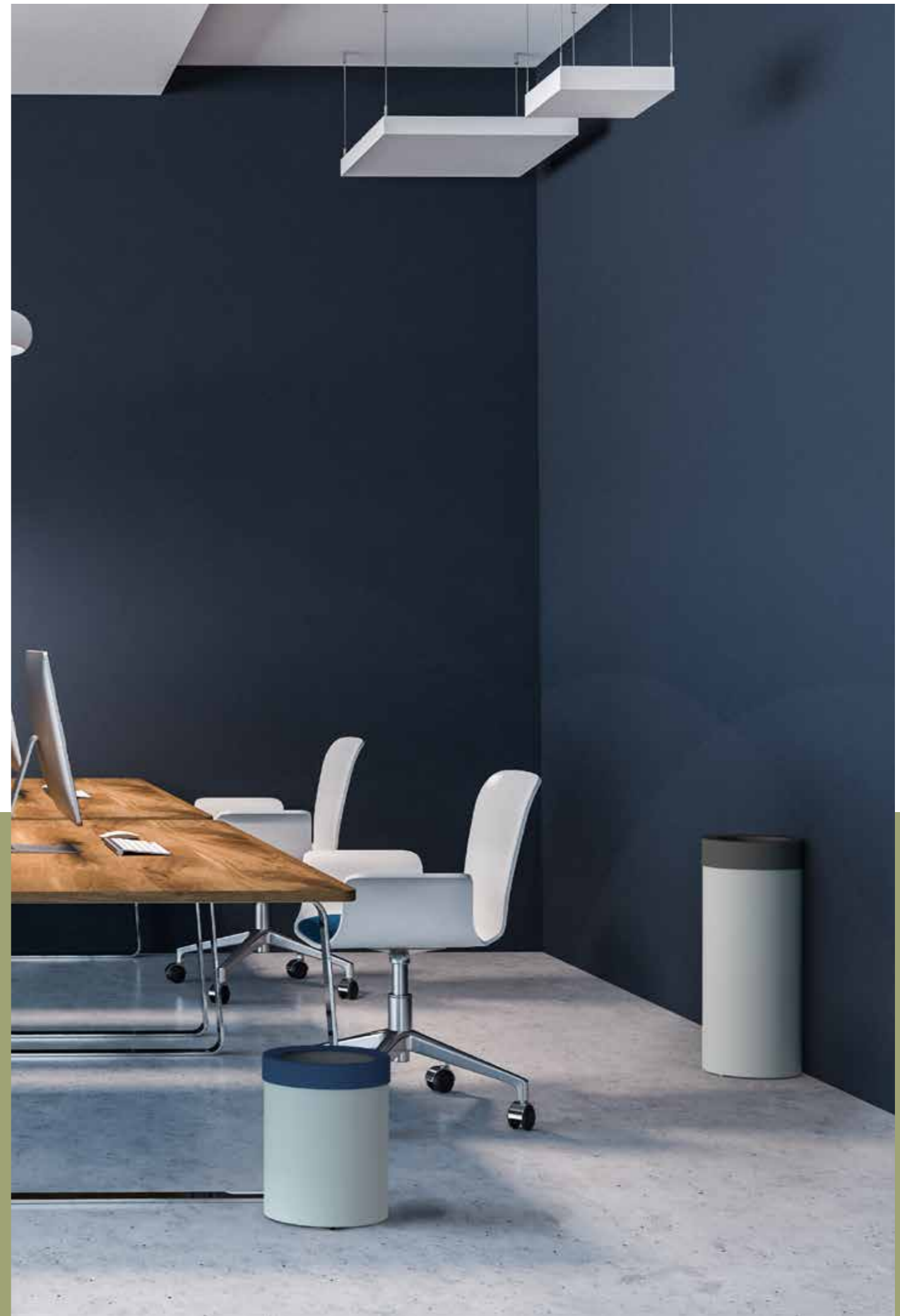

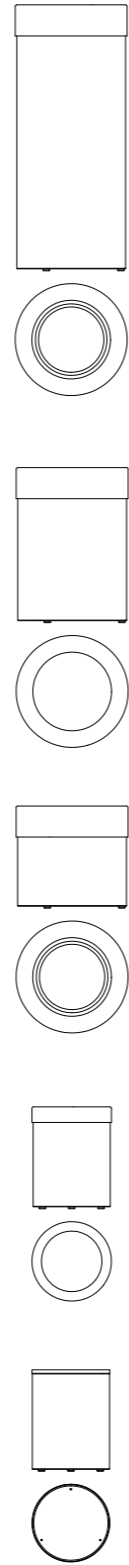

visnu

Reciclaje mural o de pie
Wall-mounted or free standing recycling

VISNU es nuestra colección de papeleras ideales para colocar en paredes o de pie y que incluye modelos con cenicero extraíble integrado en la parte superior. En la versión con cenicero la cesta es batiente para facilitar la extracción de la bolsa. En la versión sin cenicero incorpora aro porta bolsas interior y cabezal abatible.

*The **VISNU** collection of wastepaper bins is ideal for wall mounted or free-standing recycling. Some models come with a removable ashtray integrated into the top. The ashtray version has a tilting basket to make it easier to remove the bag. The version without an ashtray has an internal bin bag hoop and tilting top.*





/ 40 /

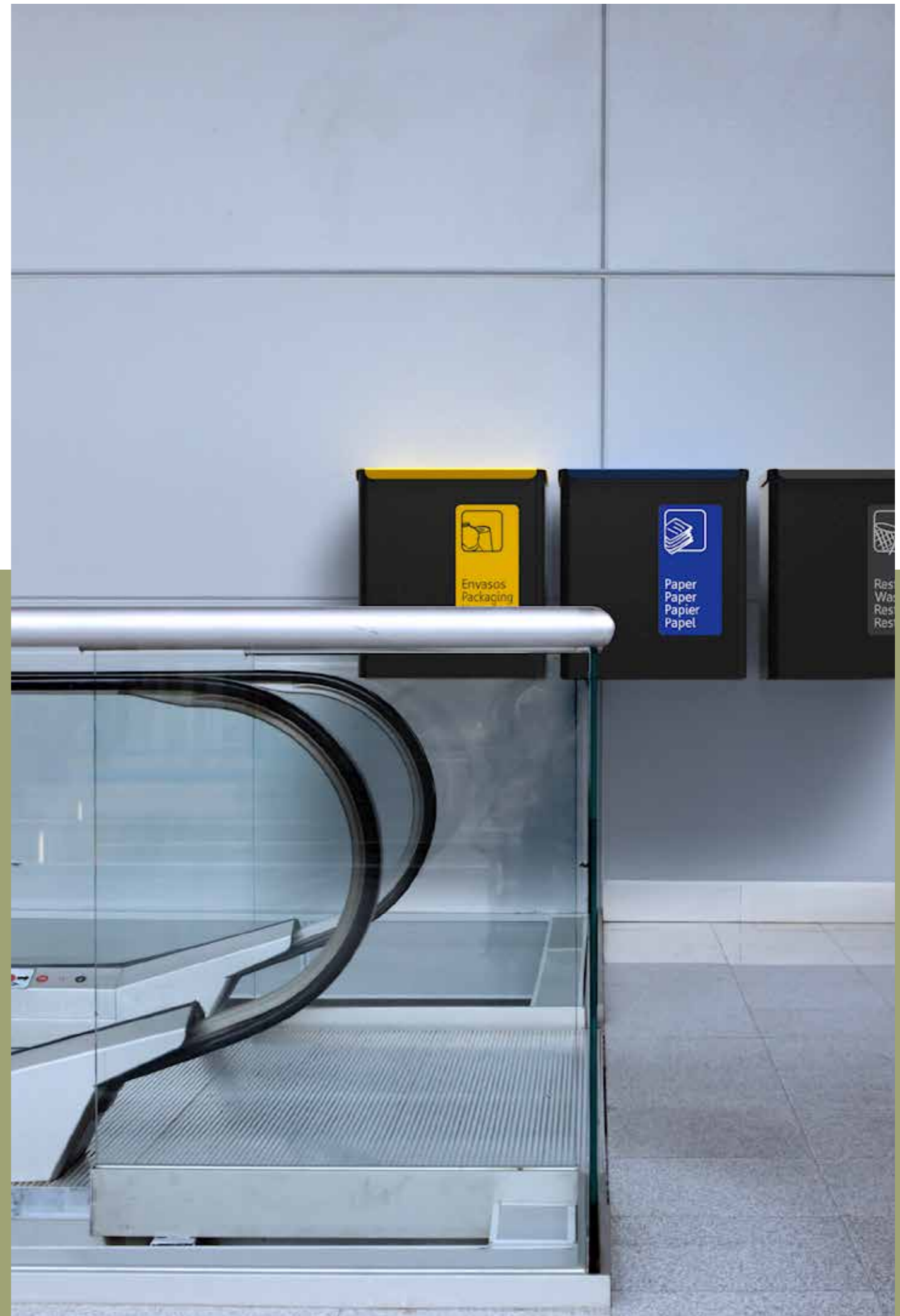

vai

Apertura con pedal Pedal opening

Para un uso cómodo del usuario, esta familia de papeleras metálicas incluye un sistema de apertura mediante pedal y un mecanismo de cierre amortiguado que evita ruidos molestos.

Están disponibles en diferentes capacidades y acabados, según su ubicación, y dispones de modelos de cuerpo opaco, perforado o con ventana transparente. Todos lo modelos incluyen aro porta bolsas. Puedes personalizarla mediante colores y vinilos, según el tipo de residuo que deban recoger.

For the comfort of the user, this range of metal wastepaper bins features a pedal opening system and a soft close mechanism to prevent loud noises. They come in different capacities and finishes depending on their location. We provide models with an opaque body, perforated body or transparent window. All models include a bin bag hoop. You can customise them with a range of colours and vinyls depending on the type of waste you wish to collect.





nala

Diseño compacto y gran capacidad
Compact design with a large capacity

La colección de papeleras **NALA** te ofrece una gran capacidad: 90 litros. Su atractivo diseño de boca superior inclinada con 1 o 2 orificios y la opción de puerta opaca o con ventana transparente, son perfectos para combinar en islas o alinear elementos y crear conjuntos de reciclaje a tu medida. Su apertura frontal y el aro porta bolsas interior facilitan la extracción y el vaciado.

*The **NALA** wastepaper bin collection provides you with a large capacity: 90 litres. With an attractive sloping lid, one or two openings and the option of an opaque door or transparent window, these bins can be perfectly combined in islands, aligned or can create bespoke recycling stations. Their front opening and internal bin bag hoop make removal and emptying easy.*



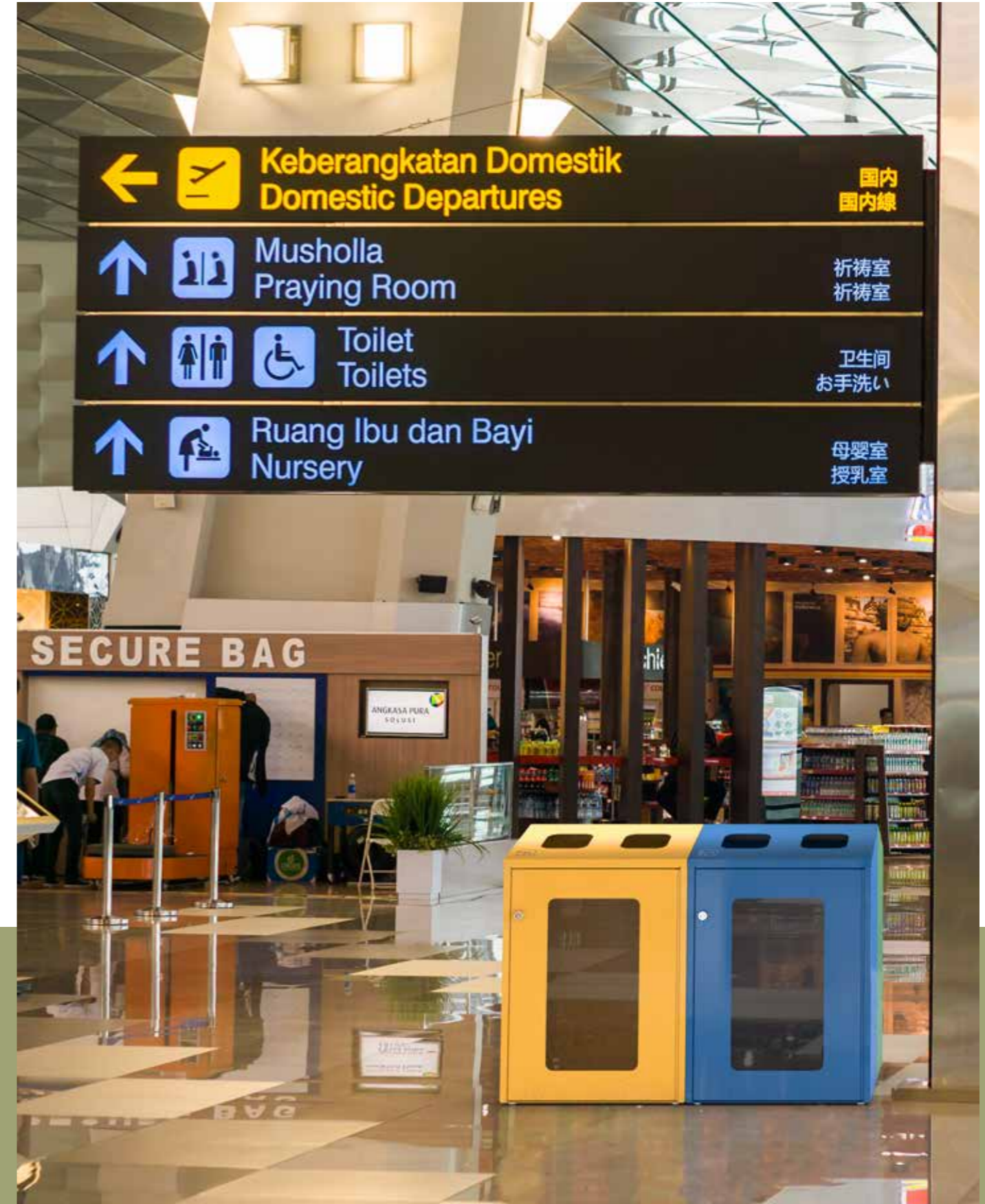
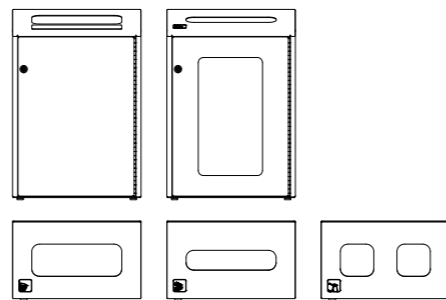

pick'up



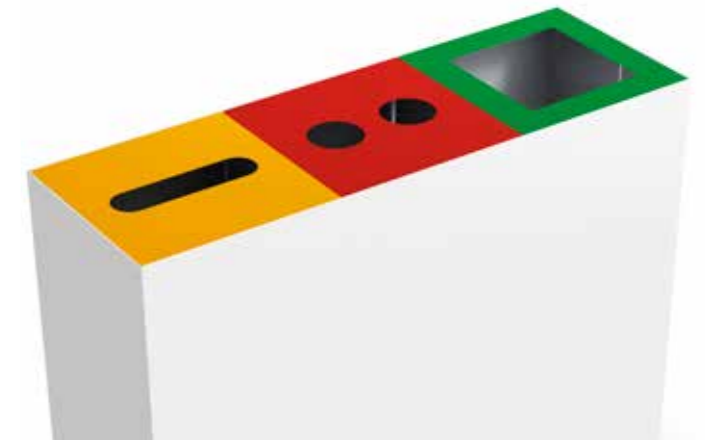
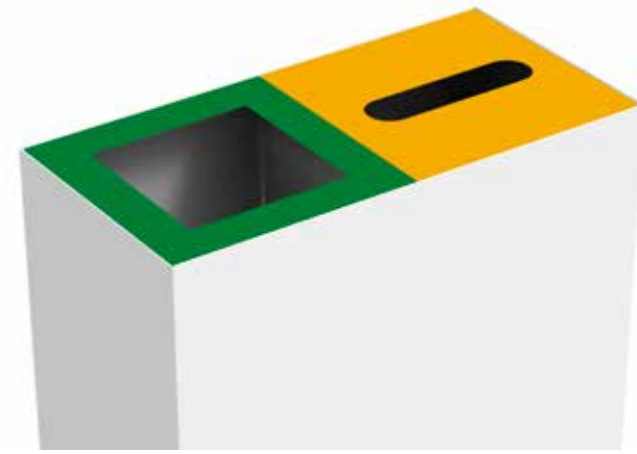

90 litros
90 liters

60 litros
60 liters

tribu

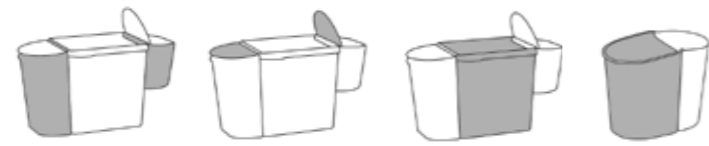

eco



clinic



step



/ 58 /



/ 59 /



gaia

Jardineras Multiformato Multiformat Planters

Las jardineras metálicas **GAIA** con macetas plásticas incorporadas permiten su combinación entre modelos y acabados.

La variedad de formatos, suelo con o sin ruedas, mural, de pie o colgante, permite una amplia posibilidad de adaptación para llenar de plantas cualquier ambiente.

GAIA metal planters with built-in plastic pots allow their combination between models and finishes.

The variety of formats, floor with or without wheels, wall-mounted, standing or hanging, allows a wide possibility of adaptation to fill any environment with plants.



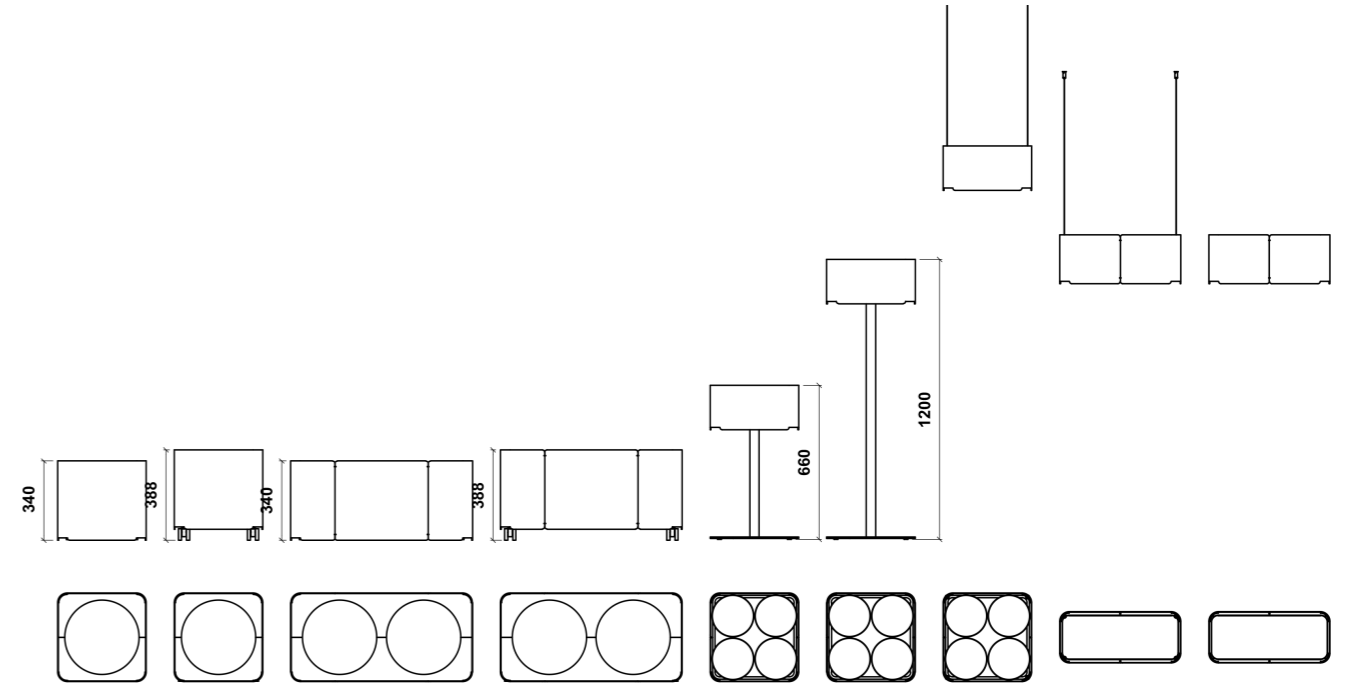
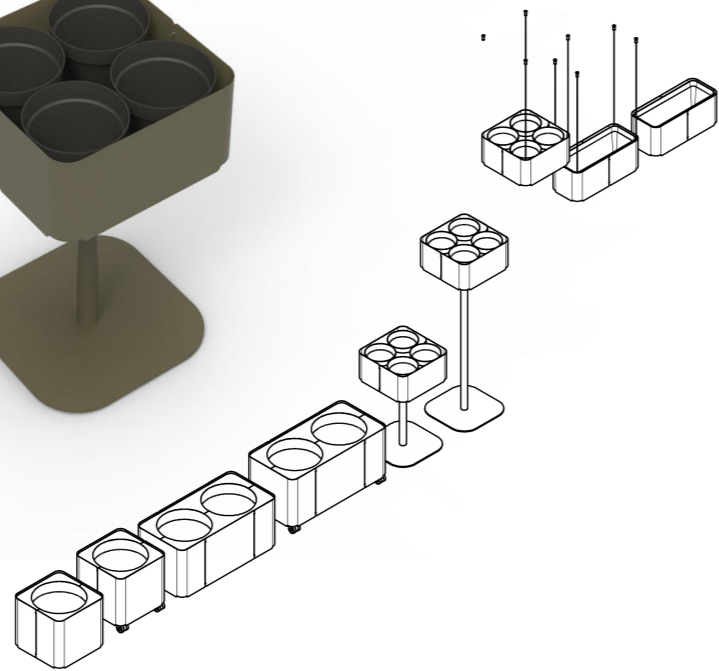
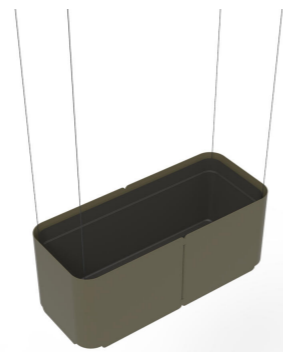
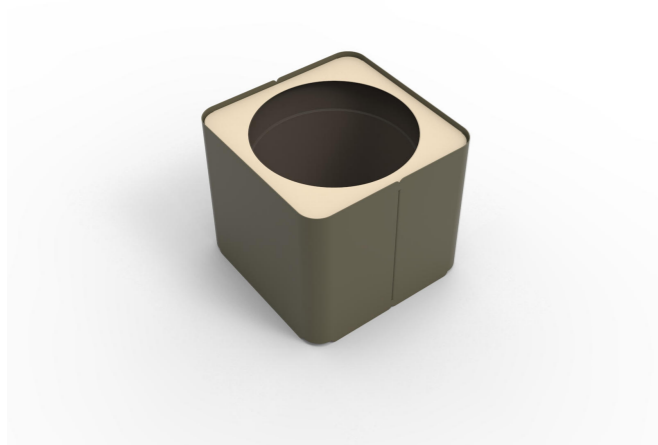

kai

Jardineras de diseño minimalista
Minimalist design planters

Las jardineras metálicas **KAI** son el complemento perfecto para las papeleras y paragüeros de la misma familia, porque su diseño minimalista se adapta a cualquier ubicación o espacio.

KAI metallic planters are the perfect complement for the wastepaper bins and umbrella stands in the same range, as their minimalist design will suit any location or space.



talía

Jardineras decorativas
Decorative planters

Estas jardineras metálicas te gustarán tanto por su diseño como por su funcionalidad. Su atractivo diseño cónico y la variedad de colores las hacen ideales para espacios comunes. Sus ruedas en la base permiten moverlas fácilmente si es necesario.

You'll love these metallic planters for both their design and their functionality. Their attractive cone-shape design and variety of colours make them ideal for common areas. They have wheels on the base so they can be moved if necessary.



pick'up



Jardineras PICK'UP: planta tú mismo PICK'UP planters: plant-it-yourself

La cubierta de la maceta cubre los bordes de esta para conseguir un acabado perfecto.
The pot cover covers the edges of the pot to achieve a neat finish.

La cubierta consta de 2 partes que hacen que encaje perfectamente en la jardinera.
The pot cover consists of 2 parts to fit easily on the planter.

Si quieres, también puedes poner una capa de mantillo.
It is an extra if you use a mulch cover.

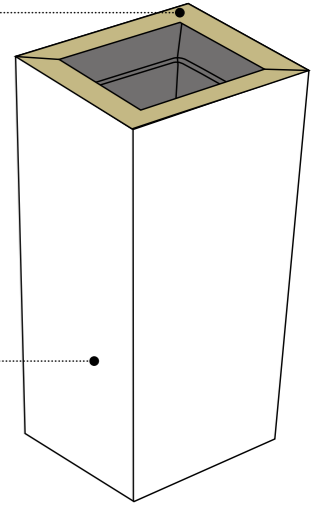

La jardinera está provista de una maceta estanca.
The planter is fitted with a watertight pot

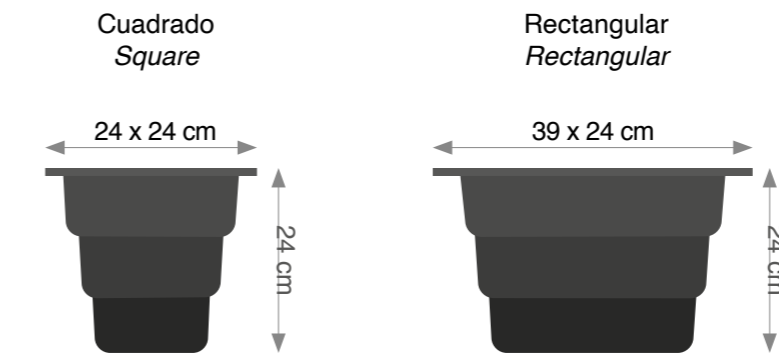

Ten en cuenta el tamaño de la maceta a la hora de elegir qué plantas comprar.
Mind the size of the pot when choosing your own plants.



nora

Atril para eventos y conferencias
Lectern for events and conferences

NORA es un atril metálico fijo con sobre inclinado para facilitar la lectura del ponente en eventos y conferencias. Su tapa extraíble facilita el cableado sin necesidad de usar herramientas y sus ruedas permiten desplazar el atril cómodamente. También incluye accesorios para personalizar gráficamente el frontal y un soporte para vaso.

***NORA** is a fixed metal lectern with an inclined top to make it easier for the speaker to read from it at events and conferences. Its removable cover facilitates wiring without the need to use tools. Because of its wheels, the lectern can be easily moved. It also includes a cup holder and accessories so that the front part can be customised with graphics.*





tea

Expositores Display stands

Para comunicaciones impresas o digitales, la familia de expositores **TEA** puede adaptarse a las dimensiones y formatos que necesites: suspensión (aéreo), mural y de pie. Su gran versatilidad te permitirá la exposición de productos, la distribución de folletos, revistas o catálogos y tablonés informativos.

*For digital or print communications, the **TEA** range of display stands can be adapted to suit the dimensions and formats you need: hanging (from above), wall-mounted or free-standing. Their great versatility gives you a place to display products, distribute leaflets, magazines and catalogues and exhibit information noticeboards.*





tab

Mesas para eventos
Tables for events

Las mesas **TAB** son la solución perfecta para tus eventos porque han sido diseñadas especialmente para facilitar su almacenamiento, transporte y montaje/desmontaje sin herramientas. Están fabricadas con una estructura metálica con niveladores que garantizan la estabilidad durante el evento y tableros de melamina con distintos acabados. También dispones de carros de almacenaje que facilitan el transporte y reducen al máximo su volumen.

***TAB** tables are the perfect solution for your events as they've been specially designed for easy storage, transport and assembly/disassembly without the need for any tools. They are made with a metal frame and furniture levellers to guarantee they remain stable throughout the event, and melamine boards with different finishes. We also do storage trolleys for ease of transport and to reduce their volume to a minimum.*





amy

Simplicidad
Simplicity

AMY es una familia de colgadores y percheros de diseño que se integra en cualquier espacio o ambiente. Disponibles en formatos de pie y pared. Con diferentes acabados y número de colgadores.

***AMY** is a range of stylish racks and hooks that will suit any room or setting. Available in free-standing and wall-mounted formats. This range come with different finishes and numbers of racks.*



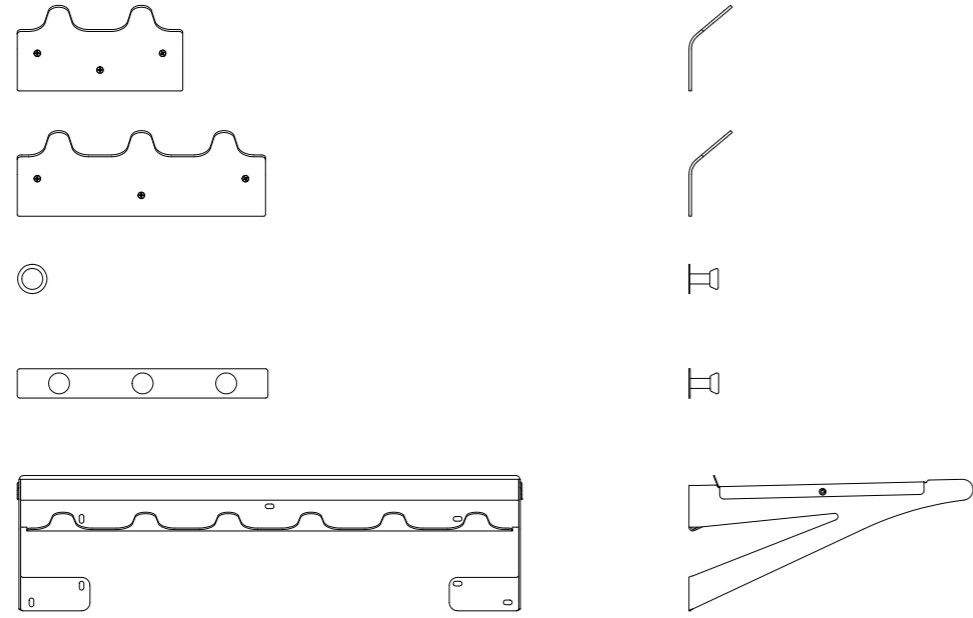

sherwood

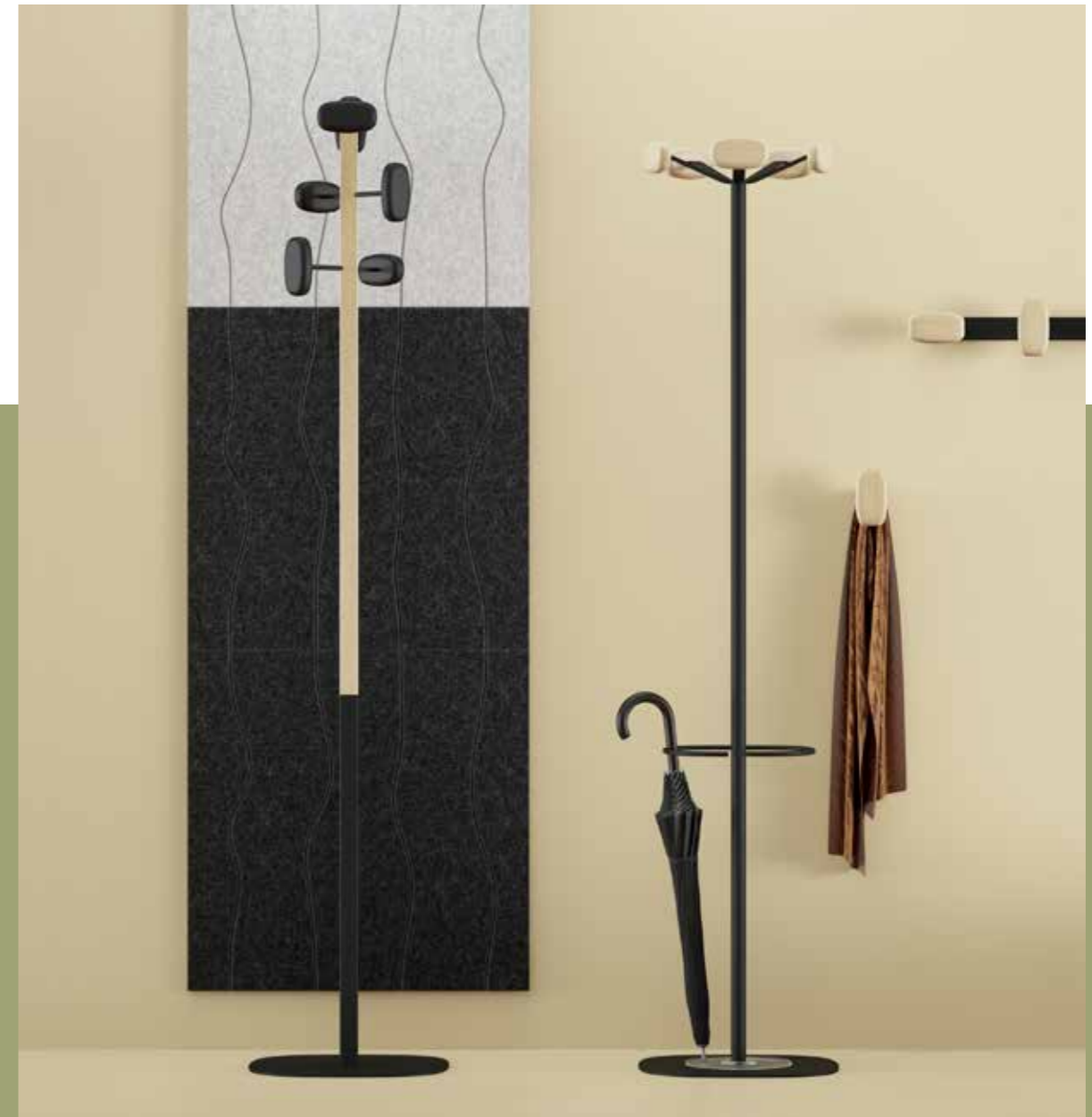
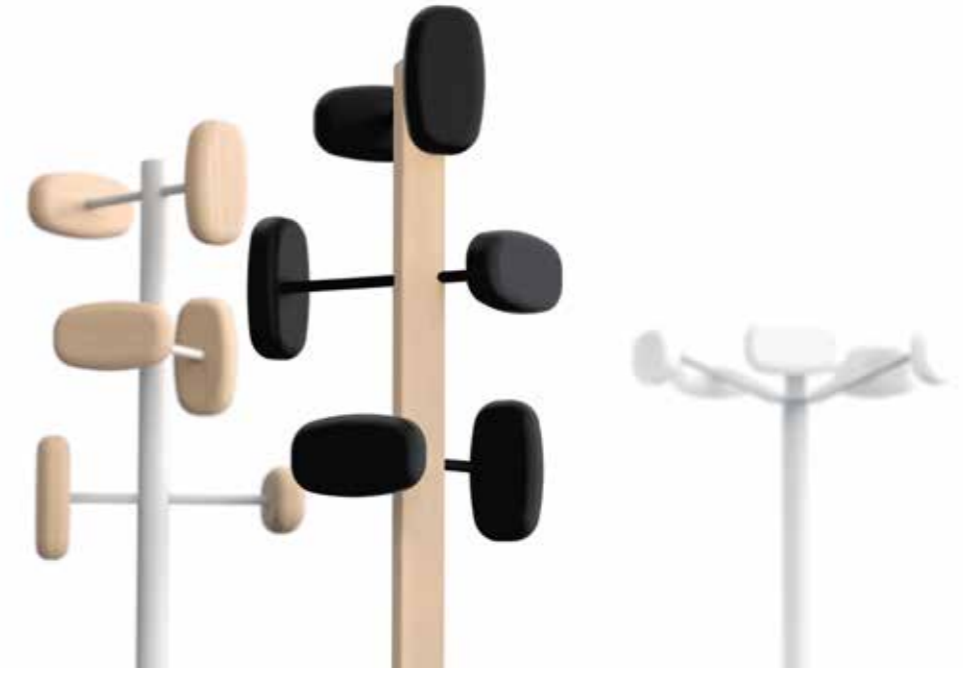

kobé



sherpa



/ 90 /

/ 91 /



arnage



/ 92 /



arnage



/ 93 /



derek

Señalética multiformato
Multiple formats of signage

La familia de elementos de señalética puede integrarse en cualquier espacio o necesidad de señalización que tengas gracias a sus múltiples formatos (sobremesa, banderola, mural y aéreo) que combinan perfectamente entre sí. Su diseño a base de una carpeta transparente ofrece una alta legibilidad y durabilidad y facilita el intercambio de los elementos gráficos si es necesario.

This range of signage products suits any room or signposting requirement you may have because of its multiple formats (desktops, banner, wall and hanging from above), which go together perfectly. The transparent file design offers a high level of legibility and durability, plus it makes it easier to exchange graphic elements when required.





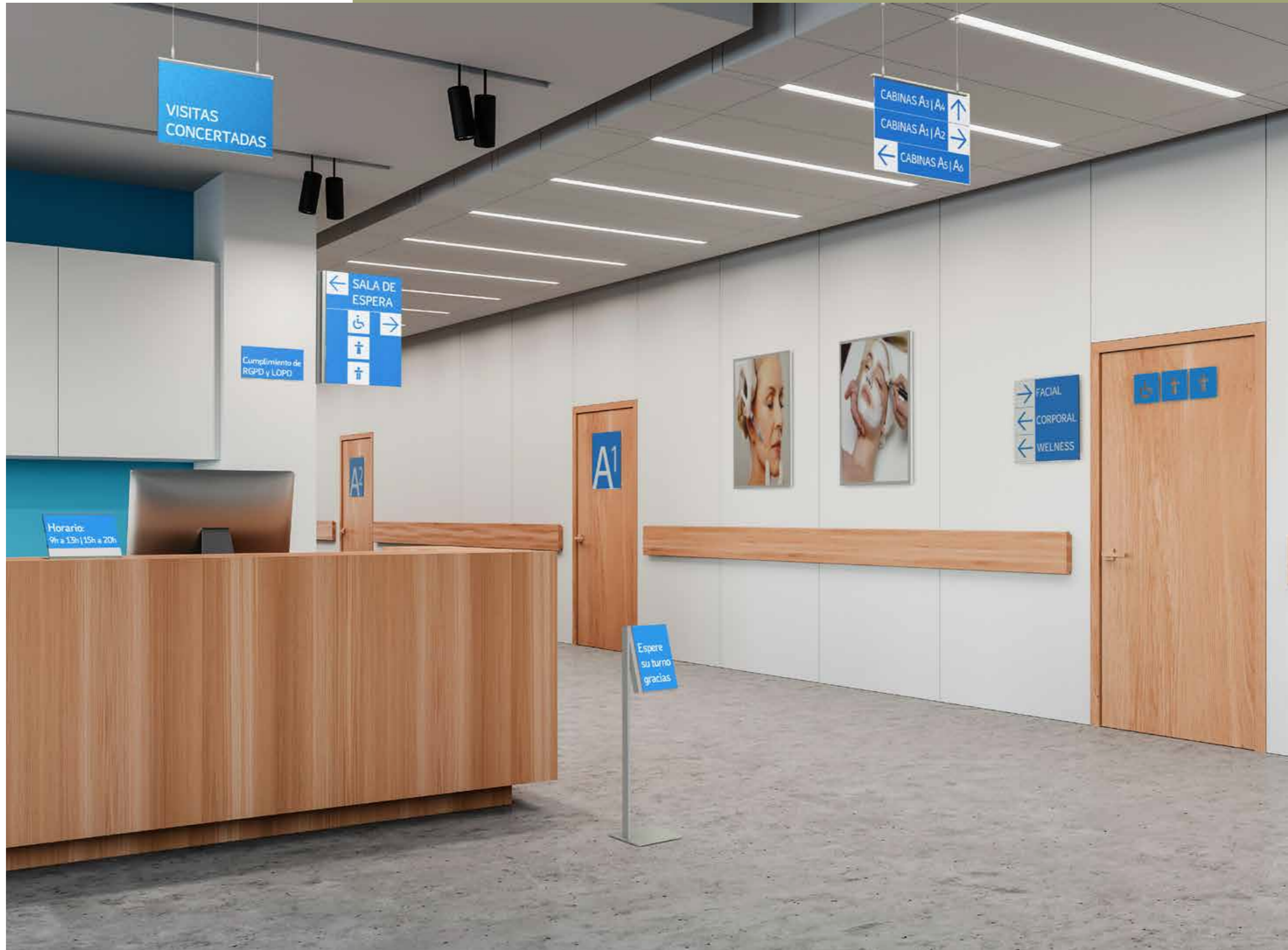

gret

Complementos de sobremesa
Desktop accessories

Diseñados en piel o símil piel, metal y con aristas redondeadas, esta familia de complementos de sobremesa ofrece un agradable tacto para el usuario y son ideales tanto para espacios contract como para el hogar.

Designed in leather or imitation leather, metal and rounded edges, this range of desktop accessories is soft to touch and ideal for both corporate spaces and the home.



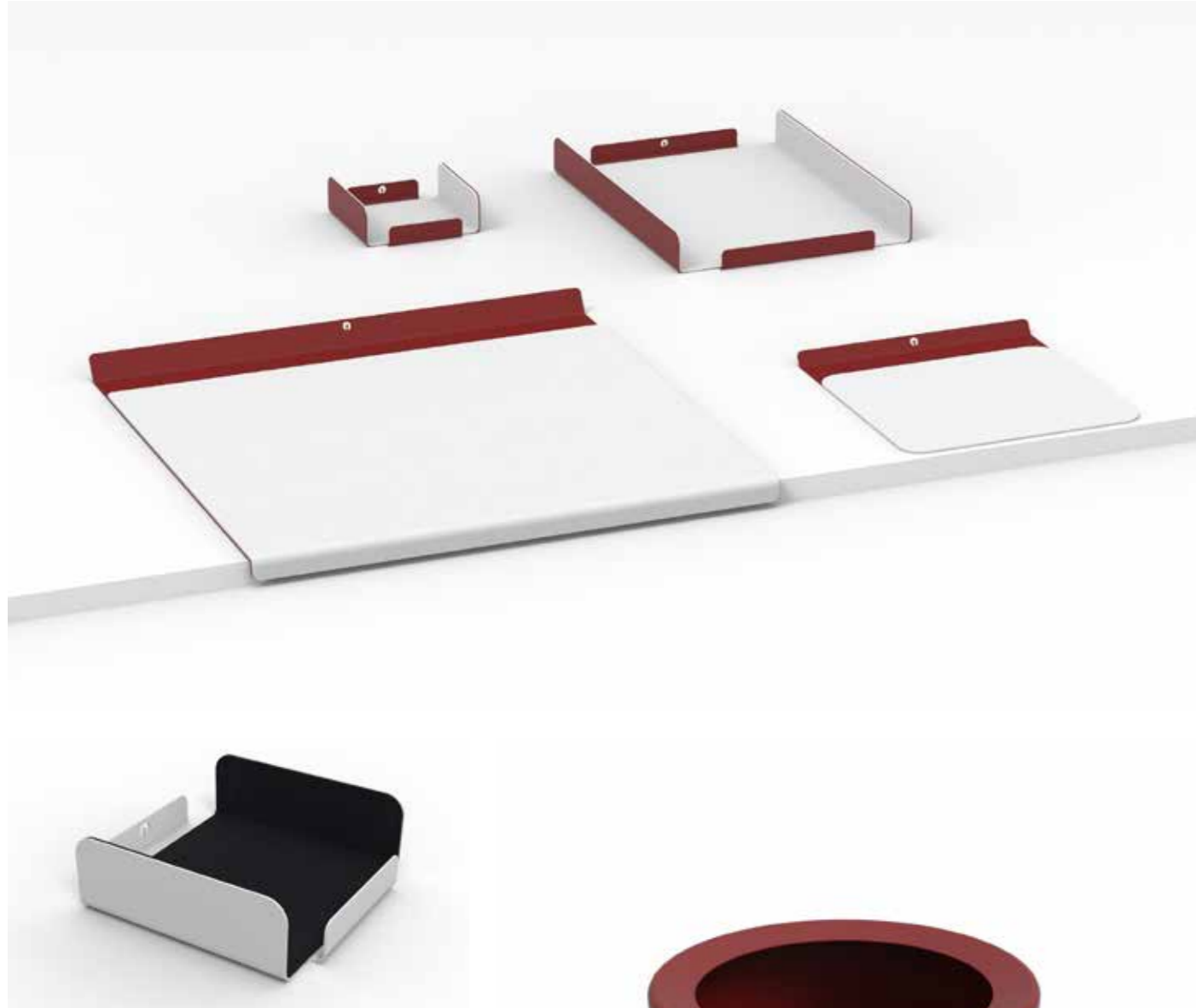

/ 102 /



youme



/ 103 /



La caja de almacenamiento YouMe permite a los trabajadores nómadas adaptarse perfectamente a nuevos entornos de trabajo.
The YouMe tool box enables mobile workers to deal peacefully with new working environments.



flo

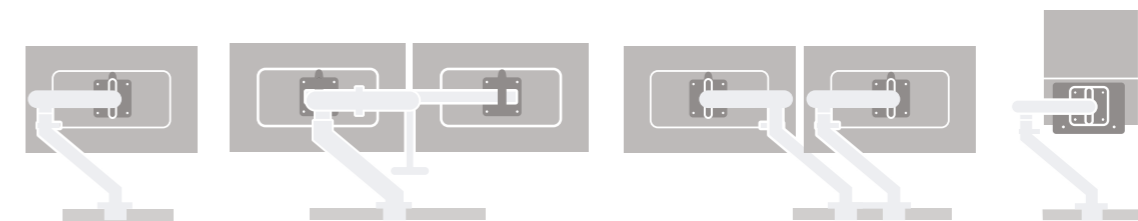
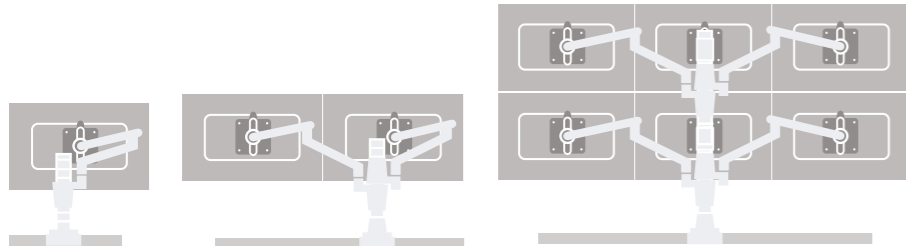

ollin

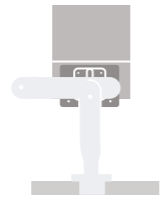
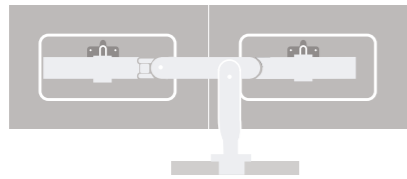
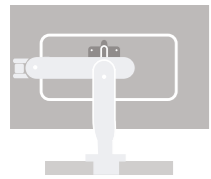

lima

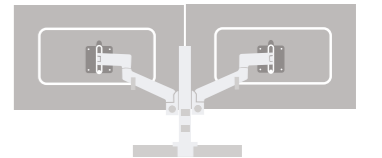
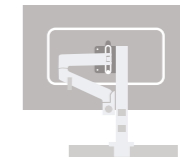

oripura

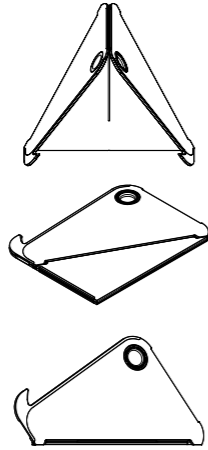

avvc

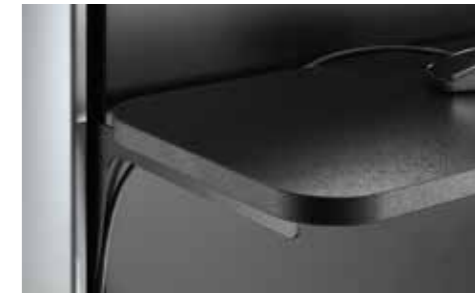

plug & play

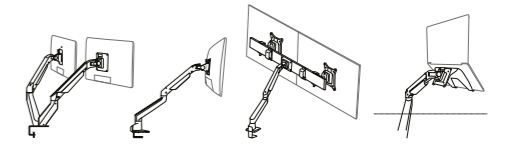
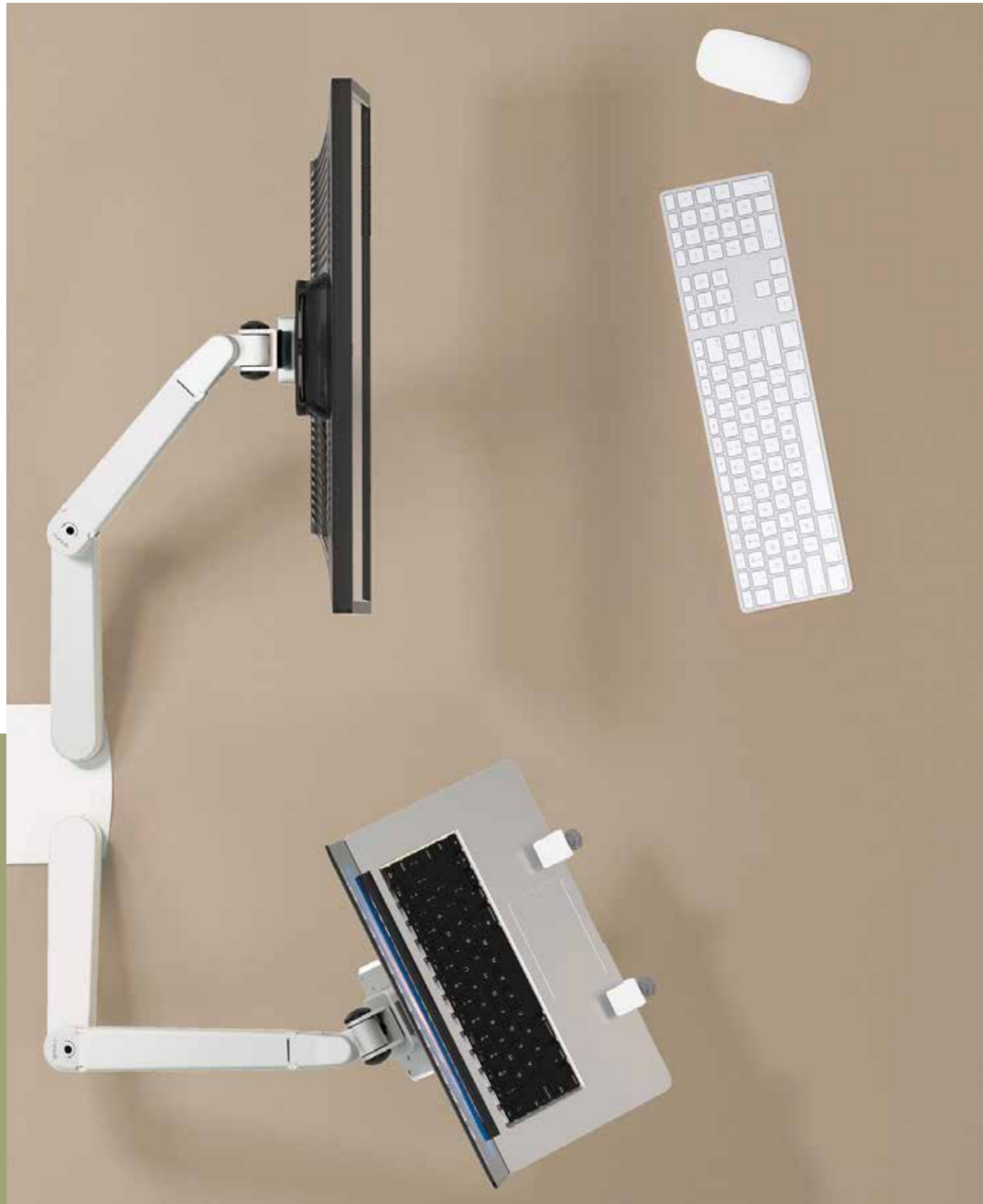

eclipse



canopée



swell

Elementos acústicos fabricados con material reciclado
Acoustic elements made from recycled material

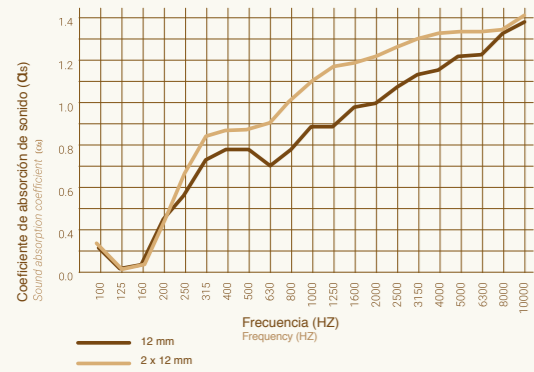

newport



oasis

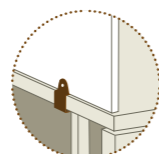

Elemento de fijación de una cara
One-sided clamps

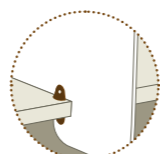

Elemento de fijación para
pantallas laterales móviles
*Clamps for mobile
side screens*

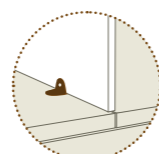

Elemento de fijación de dos caras
Two-sided clamps

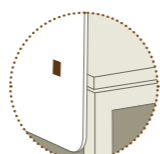

Elemento de fijación
para panel frontal
*Clamps for
modesty screen*



windo



madison

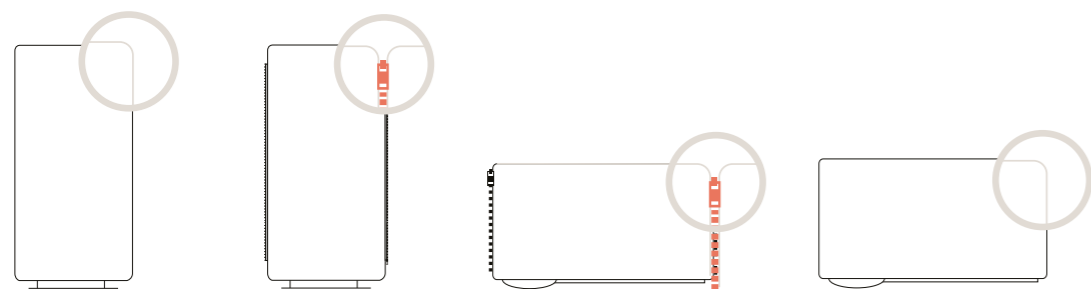

kp+



ke



addenda

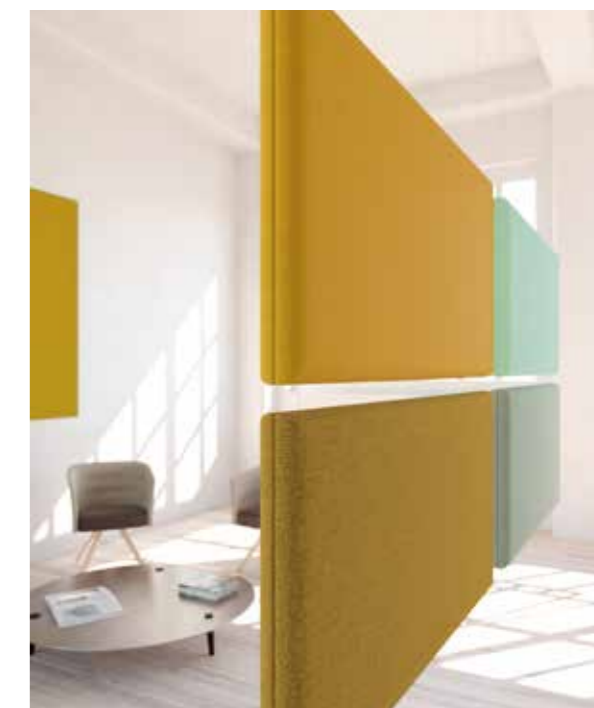
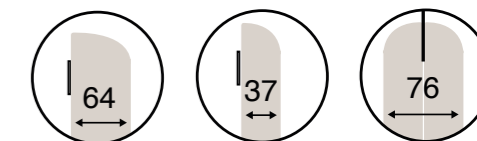

scoop

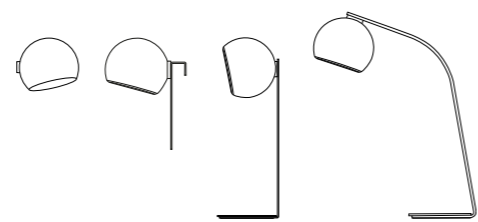

ipn

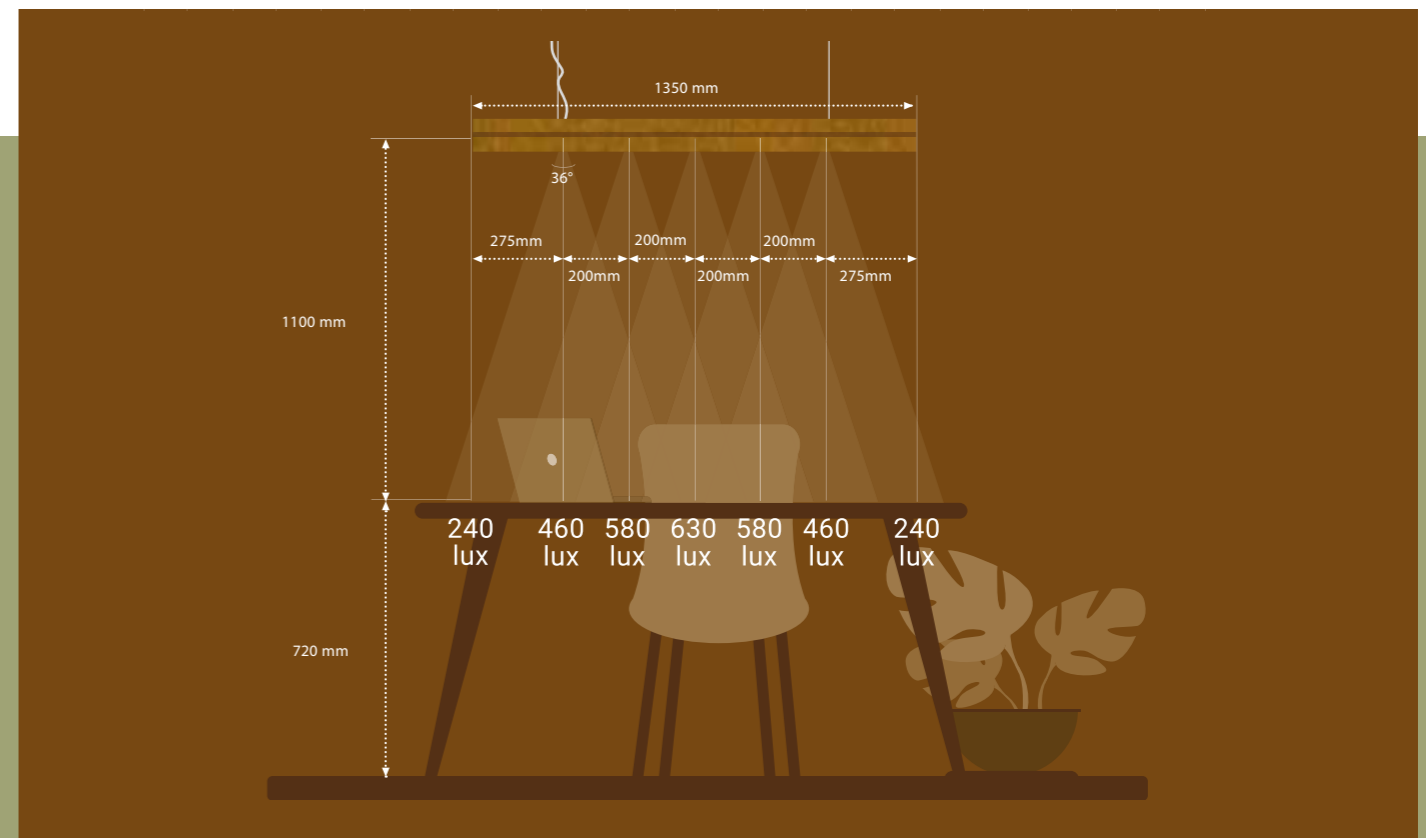

Soluciones
a medida
para cualquier
espacio
contract

*Bespoke
solutions
for any
corporate
space*







www.unnom.es